

Valves

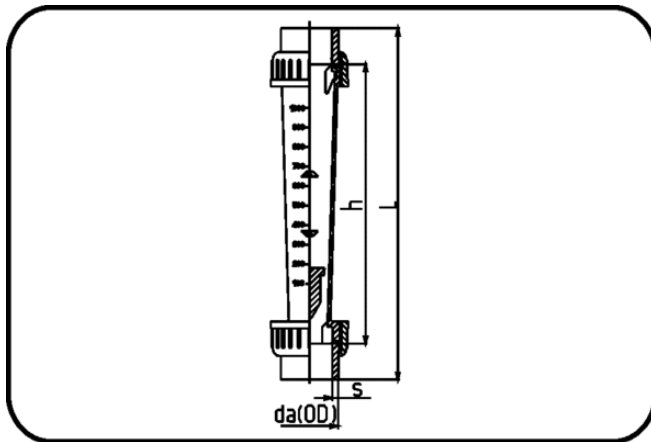

Code: 246

- **Flow Meter M123**
- FPM-sealing PSU-measuring tube
- injection moulded
- **Butt + IR-welding**
- **PP Pure grey**

Dimension	Code	Detail	da(OD) mm	s mm	L mm	h mm	p bar	DN mm	Weight
20	72.246.0120.11	20-SDR11 MOP 10bar 8-80l/h	20	1,9	293	185	10	15	0.14
20	72.246.0220.11	20-SDR11 MOP 10bar 15-150l/h	20	1,9	293	185	10	15	0.13
20	72.246.0320.11	20-SDR11 MOP 10bar 20-200l/h	20	1,9	293	185	10	15	0.13
32	72.246.0132.11	32-SDR11 MOP 10bar 15-150l/h	32	2,9	320	200	10	25	0.24
32	72.246.0232.11	32-SDR11 MOP 10bar 30-300l/h	32	2,9	320	200	10	25	0.31
32	72.246.0332.11	32-SDR11 MOP 10bar 50-500l/h	32	2,9	320	200	10	25	0.30
32	72.246.0432.11	32-SDR11 MOP 10bar 100-1000l/h	32	2,9	320	200	10	25	0.27