

Valves

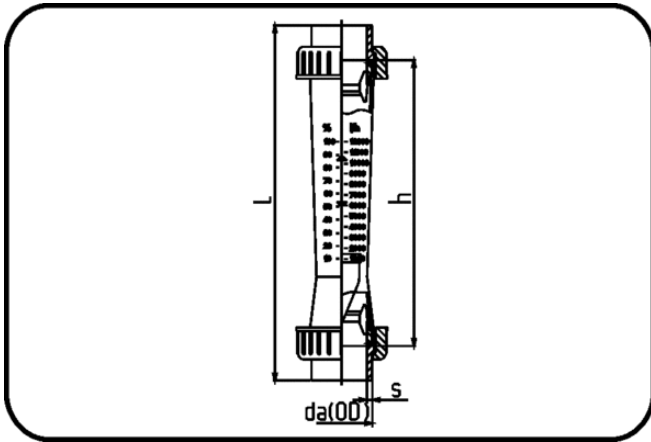

Code: 247.1

- Flow Meter M335
- FPM-sealing PSU-measuring tube
- injection moulded
- **Butt + IR-welding**
- **PVDF UHP natural**

Dimension	Code	Detail	da(OD) mm	s mm	L mm	h mm	p bar	DN mm	Weight
32	35.247.1132.21	32-SDR21 MOP 10bar 50-500l/h	32	2,4	443	335	10	25	0.59
32	35.247.1232.21	32-SDR21 MOP 10bar 100-1000l/h	32	2,4	443	335	10	25	0.60
40	35.247.1140.21	40-SDR21 MOP 10bar 150-1500l/h	40	2,4	461	335	10	32	0.66
40	35.247.1240.21	40-SDR21 MOP 10bar 250-2500l/h	40	2,4	461	335	10	32	0.55
50	35.247.1150.21	50-SDR21 MOP 10bar 200-2000l/h	50	3	459	335	10	40	1.05
50	35.247.1250.21	50-SDR21 MOP 10bar 300-3000l/h	50	3	459	335	10	40	1.03
50	35.247.1350.21	50-SDR21 MOP 10bar 600-6000l/h	50	3	459	335	10	40	0.99
63	35.247.1163.21	63-SDR21 MOP 10bar 600-6000l/h	63	3	461	335	10	50	1.47
63	35.247.1263.21	63-SDR21 MOP 10bar1000-10000lh	63	3	461	335	10	50	1.19
63	35.247.1363.21	63-SDR21 MOP 10bar1500-15000lh	63	3	461	335	10	50	1.27
75	35.247.1175.21	75-SDR21 MOP 10bar2000-20000lh	75	3,6	453	335	10	65	3.00
75	35.247.1275.21	75-SDR21 MOP 10bar3000-30000lh	75	3,6	453	335	10	65	2.90
75	35.247.1375.21	75-SDR21 MOP 10bar8000-60000lh	75	3,6	453	335	10	65	2.64