

Fittings

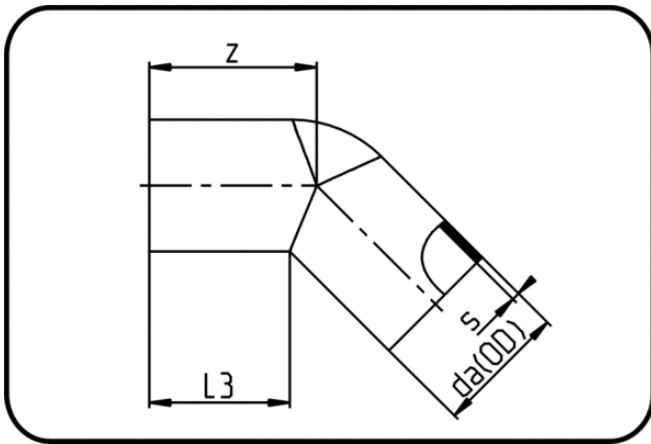

Code: 060

- **Elbow 45°**
- long spigot
- injection moulded
- **Butt + IR-welding**
- **PVDF UHP natural**

Dimension	Code	Detail	da(OD) mm	s mm	z mm	L3 mm	Weight
90	35.060.0090.33	90X2,8 SDR33 ISO S-16	90	2,8	59	36	0.17
110	35.060.0110.33	110X3,4 SDR33 ISO S-16	110	3,4	68	45	0.31
140	35.060.0140.33	140X4,3 SDR33 ISO S-16	140	4,3	85	57	0.64
160	35.060.0160.33	160X4,9 SDR33 ISO S-16	160	4,9	103	65	0.94
20	35.060.0020.21	20X1,9 SDR21 ISO S-10	20	1,9	43	39	0.02
25	35.060.0025.21	25X1,9 SDR21 ISO S-10	25	1,9	45	40	0.03
32	35.060.0032.21	32X2,4 SDR21 ISO S-10	32	2,4	52	46	0.05
40	35.060.0040.21	40X2,4 SDR21 ISO S-10	40	2,4	58	50	0.07
50	35.060.0050.21	50X3,0 SDR21 ISO S-10	50	3	66	56	0.12
63	35.060.0063.21	63X3,0 SDR21 ISO S-10	63	3	75	62	0.18
75	35.060.0075.21	75X3,6 SDR21 ISO S-10	75	3,6	50	32	0.15
90	35.060.0090.21	90X4,3 SDR21 ISO S-10	90	4,3	59	36	0.24
110	35.060.0110.21	110X5,3 SDR21 ISO S-10	110	5,3	68	45	0.46
140	35.060.0140.21	140X6,7 SDR21 ISO S-10	140	6,7	85	57	0.96
160	35.060.0160.21	160X7,7 SDR21 ISO S-10	160	7,7	103	65	1.39