

## Saddles

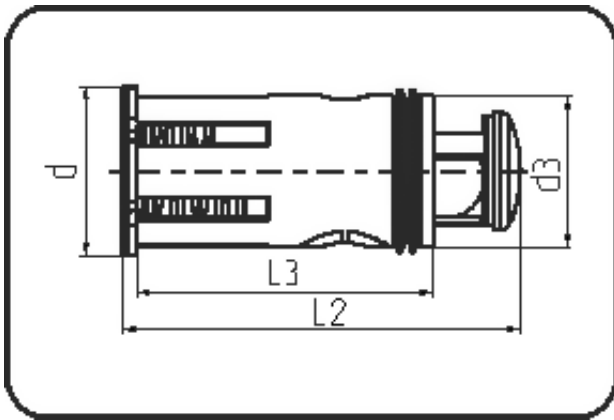

Code: 272

- **Gas-Lock**
- Gas excess flow valve
- pressure range: 1-5bar yellow
- injection moulded
- **PPA**

| Dimension | Code           | Detail          | Weight |
|-----------|----------------|-----------------|--------|
| 32        | 9P.272.1032.00 | 32 1-5 bar D100 | 0.02   |

|        | Unit | Nominale | Tol+ | Tol- |
|--------|------|----------|------|------|
| da(OD) | mm   | 32       | 0.30 | 0.00 |
| L3     | mm   | 48,6     | 0.10 | 1.00 |
| L2     | mm   | 65,5     | 0.10 | 1.00 |
| d      | mm   | 27,8     | 0.05 | 0.05 |
| d3     | mm   | 24,8     | 0.10 | 0.10 |