

Saddles

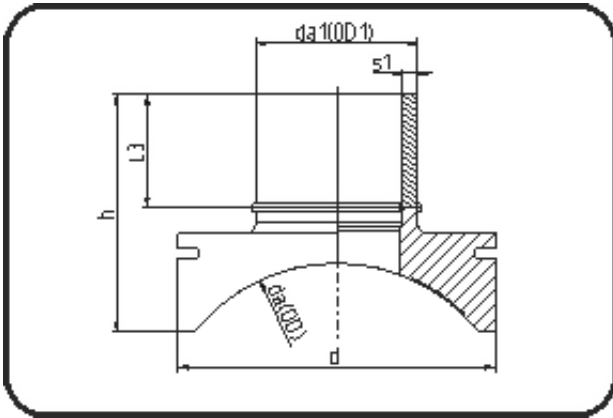

Code: 289

- **Spigot saddle System Topload**

- machined
- **Electro-fusion**
- **PE 100-RC black**

Other MOP on request. Installation Set please see Welding Technology.

Dimension	Code	Detail	Weight
560/90	70.289.5690.09	560/90 SDR9 MOP 16 bar	1.13

	Unit	Nominale	Tol+	Tol-
da(OD)	mm	560	0.00	0.00
L3	mm	94	15.00	0.00
d	mm	200	1.50	1.50
s1	mm	10,1	2.20	0.00
h	mm	168	15.00	0.00
da(OD1)	mm	90	1.40	0.00