

Saddles

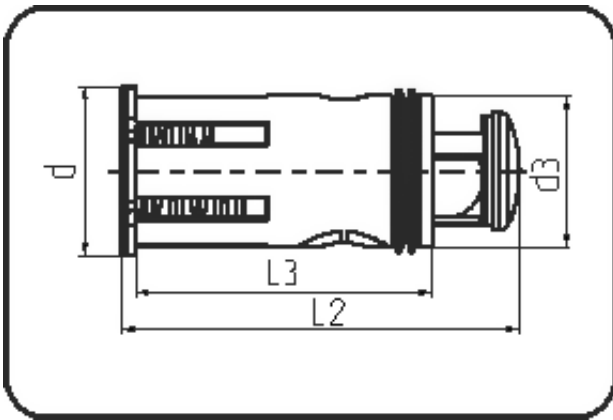

Code: 272

- **Gas-Lock**
- Gas excess flow valve
- pressure range: 1-5bar yellow
- injection moulded
- **PPA**

Dimension	Code	Detail	Weight
20	9P.272.1020.00	20 1-5 bar D25	0.01

	Unit	Nominale	Tol+	Tol-
da(OD)	mm	20	0.30	0.00
L3	mm	40,2	0.10	1.00
L2	mm	52,5	0.10	1.00
d	mm	17	0.00	0.00
d3	mm	12,9	0.15	0.15