

Saddles

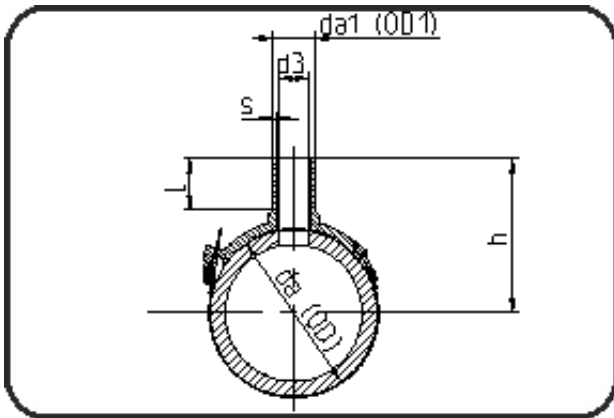

Code: 288

- Spigot saddle
- MOP water 16bar/gas 10bar
- W/P-TW
- injection moulded
- **Electro-fusion**
- **PE 100-RC black**

Dimension	Code	Detail	Weight
315/90	70.288.3190.11	315/90 SDR 17 - 11	1.06

	Unit	Nominale	Tol+	Tol-
da(OD)	mm	315	0.00	0.00
L	mm	92	1.50	1.50
b	mm	326,5	0.00	0.00
s	mm	8,2	1.00	0.00
alph	[°]	30	0.00	0.00
d3	mm	65	0.00	0.00
h	mm	285	0.00	0.00
da(OD1)	mm	90	0.60	0.00