

Saddles

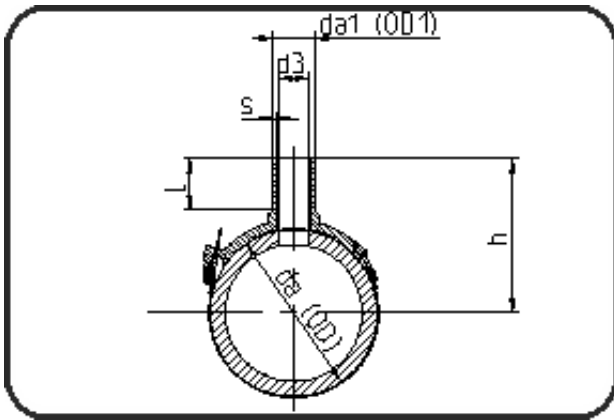

Code: 288

- Spigot saddle
- MOP water 16bar/gas 10bar
- W/P-TW
- injection moulded
- **Electro-fusion**
- **PE 100-RC black**

Dimension	Code	Detail	Weight
250/63	70.288.2563.11	250/63 SDR 17 - 11	0.62

	Unit	Nominale	Tol+	Tol-
da(OD)	mm	250	0.00	0.00
L	mm	77,5	1.50	1.50
b	mm	266	0.00	0.00
s	mm	5,8	0.70	0.00
alph	[°]	40	0.00	0.00
d3	mm	45	0.00	0.00
h	mm	231	0.00	0.00
da(OD1)	mm	63	0.40	0.00