

Saddles

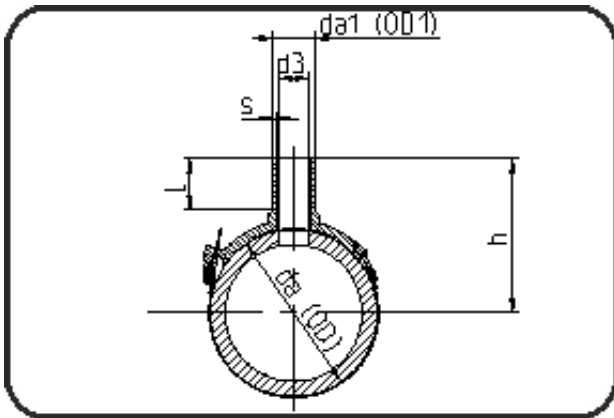

Code: 288

- Spigot saddle
- MOP water 16bar/gas 10bar
- W/P-TW
- injection moulded
- **Electro-fusion**
- **PE 100-RC black**

| Dimension | Code | Detail | Weight |
|-----------|----------------|---------------------|--------|
| 160/110 | 70.288.1611.11 | 160/110 SDR 17 - 11 | 0.95 |

| | Unit | Nominale | Tol+ | Tol- |
|---------|------|----------|------|------|
| da(OD) | mm | 160 | 0.00 | 0.00 |
| L | mm | 98 | 1.50 | 1.50 |
| b | mm | 196,5 | 0.00 | 0.00 |
| s | mm | 10 | 1.10 | 0.00 |
| alph | [°] | 0 | 0.00 | 0.00 |
| d3 | mm | 84 | 0.00 | 0.00 |
| h | mm | 202 | 0.00 | 0.00 |
| da(OD1) | mm | 110 | 0.70 | 0.00 |