

Saddles

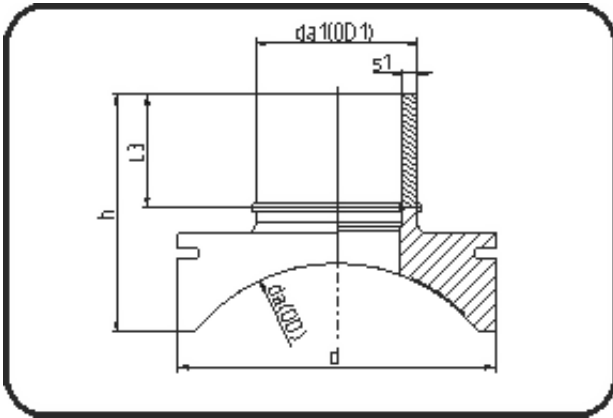

Code: 289

- **Spigot saddle System Topload**

- machined
- **Electro-fusion**
- **PE 100-RC black**

Other MOP as well as further dimensions on request. Installation Set please see Welding Technology.

Dimension	Code	Detail	Weight
1000/200	70.289.1020.11	1000/200 SDR11 MOP 16 bar	8.20

	Unit	Nominale	Tol+	Tol-
da(OD)	mm	1.000	0.00	0.00
L3	mm	127	10.00	0.00
d	mm	400	1.00	1.00
s1	mm	18,2	2.00	0.00
h	mm	246	10.00	0.00
da(OD1)	mm	200	1.20	0.00