

Saddles

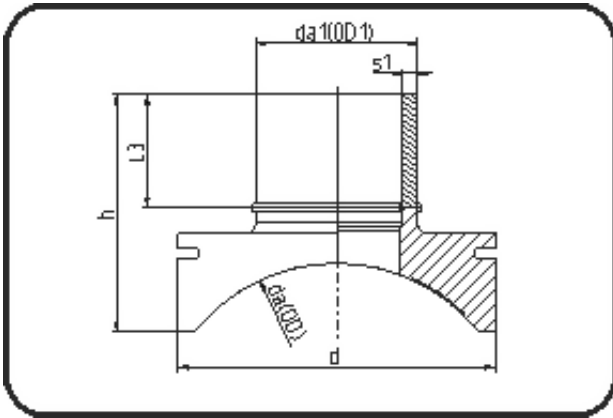

Code: 289

- **Spigot saddle System Topload**

- machined
- **Electro-fusion**
- **PE 100-RC black**

Other MOP on request. Installation Set please see Welding Technology.

Dimension	Code	Detail	Weight
450/125	70.289.4512.11	450/125 SDR11 MOP 16 bar	3.30

	Unit	Nominale	Tol+	Tol-
da(OD)	mm	450	0.00	0.00
L3	mm	102	15.00	0.00
d	mm	280	1.50	1.50
s1	mm	11,4	1.30	0.00
h	mm	199	15.00	0.00
da(OD1)	mm	125	0.80	0.00