

Saddles

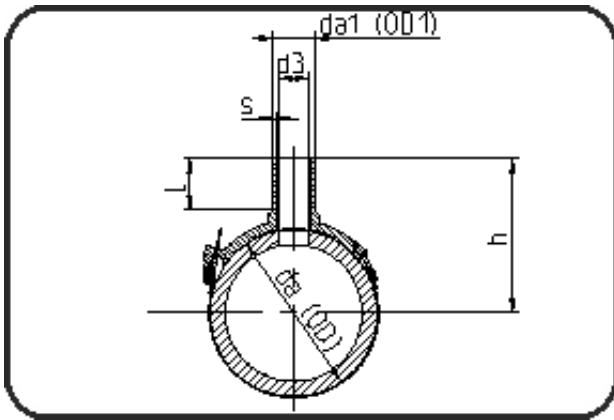

Code: 288

- Spigot saddle
- MOP water 16bar/gas 10bar
- W/P-TW
- injection moulded
- **Electro-fusion**
- **PE 100-RC black**

| Dimension | Code | Detail | Weight |
|-----------|----------------|--------------------|--------|
| 250/50 | 70.288.2550.11 | 250/50 SDR 17 - 11 | 0.38 |

| | Unit | Nominale | Tol+ | Tol- |
|---------|------|----------|------|------|
| da(OD) | mm | 250 | 0.00 | 0.00 |
| L | mm | 72 | 1.00 | 1.00 |
| b | mm | 242 | 0.00 | 0.00 |
| s | mm | 4,6 | 0.60 | 0.00 |
| alph | [°] | 40 | 0.00 | 0.00 |
| d3 | mm | 36 | 0.00 | 0.00 |
| h | mm | 231 | 0.00 | 0.00 |
| da(OD1) | mm | 50 | 0.40 | 0.00 |