

Saddles

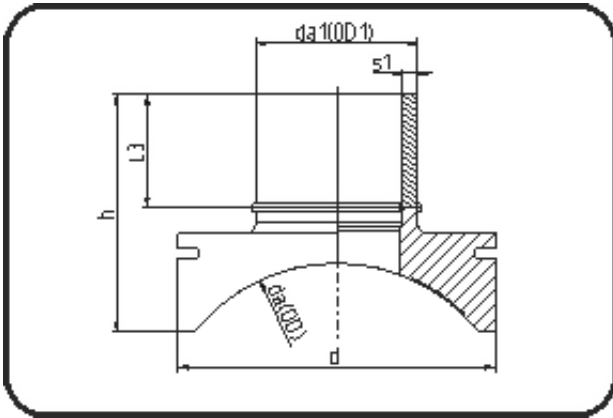

Code: 289

- **Spigot saddle System Topload**

- machined
- **Electro-fusion**
- **PE 100-RC black**

Other MOP on request. Installation Set please see Welding Technology.

Dimension	Code	Detail	Weight
630/110	70.289.6311.09	630/110 SDR9 MOP 16 bar	2.04

	Unit	Nominale	Tol+	Tol-
da(OD)	mm	630	0.00	0.00
L3	mm	97	15.00	0.00
d	mm	250	1.50	1.50
s1	mm	12,3	2.20	0.00
h	mm	176	15.00	0.00
da(OD1)	mm	110	1.40	0.00