

## Saddles

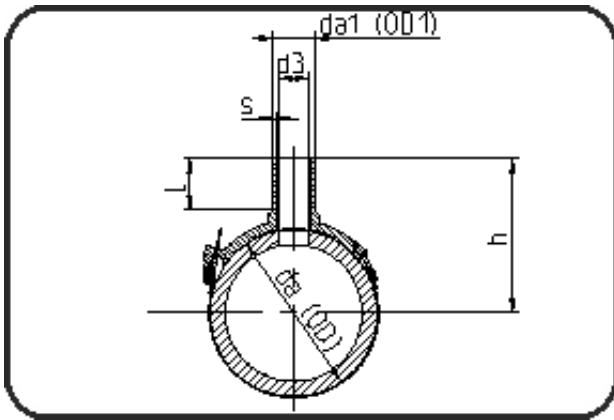

Code: 288

- Spigot saddle
- MOP water 16bar/gas 10bar
- W/P-TW
- injection moulded
- **Electro-fusion**
- **PE 100-RC black**

Dimension	Code	Detail	Weight
280/110	70.288.2811.11	280/110 SDR 17 - 11	1.07

	Unit	Nominale	Tol+	Tol-
da(OD)	mm	280	0.00	0.00
L	mm	98	1.00	1.00
b	mm	305	0.00	0.00
s	mm	10	1.10	0.00
alph	[°]	30	0.00	0.00
d3	mm	84	0.00	0.00
h	mm	251	0.00	0.00
da(OD1)	mm	110	0.70	0.00