

Saddles

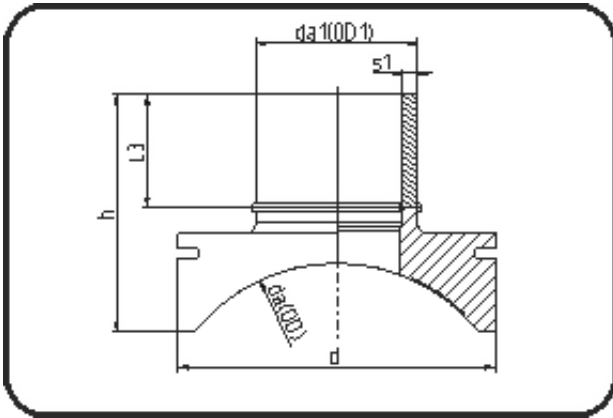

Code: 289

- **Spigot saddle System Topload**

- machined
- **Electro-fusion**
- **PE 100-RC black**

Other MOP as well as further dimensions on request. Installation Set please see Welding Technology.

Dimension	Code	Detail	Weight
500/110	70.289.5011.11	500/110 SDR11 MOP 16 bar	2.00

	Unit	Nominale	Tol+	Tol-
da(OD)	mm	500	0.00	0.00
L3	mm	97	10.00	0.00
d	mm	250	1.00	1.00
s1	mm	10	1.10	0.00
h	mm	182	10.00	0.00
da(OD1)	mm	110	0.70	0.00