

Saddles

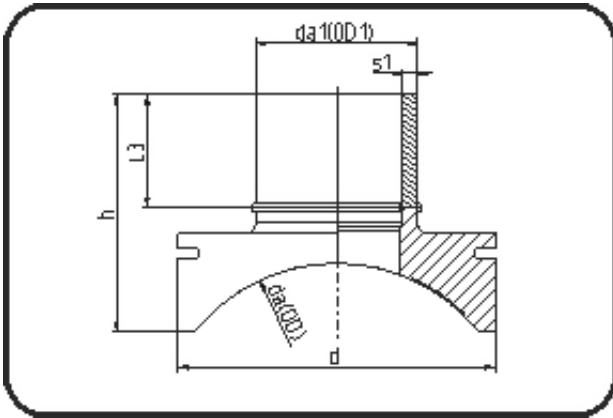

Code: 289

- **Spigot saddle System Topload**

- machined
- **Electro-fusion**
- **PE 100-RC black**

Other MOP as well as further dimensions on request. Installation Set please see Welding Technology.

Dimension	Code	Detail	Weight
900/280	70.289.9028.11	900/280 SDR11 MOP 16 bar	13.60

	Unit	Nominale	Tol+	Tol-
da(OD)	mm	900	0.00	0.00
L3	mm	154	15.00	0.00
d	mm	500	1.50	1.50
s1	mm	25,4	2.70	0.00
h	mm	293	15.00	0.00
da(OD1)	mm	280	1.70	0.00