

## SURELINE II Pipes

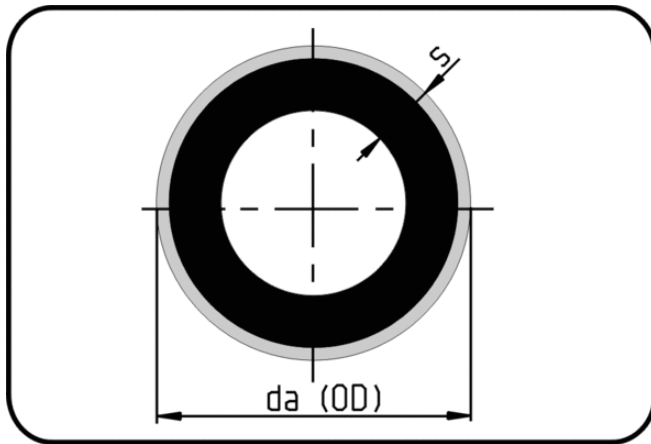

Code: 712.3

- Pipe black 12m
- with orange signal layer
- extruded
- PE 100-RC SURELINE II

Not available from stock - delivery time on request.

Dimension	Code	Detail	da(OD) mm	s mm	Weight
75	70.712.3075.17	75X4,5 SDR17 ISO S-8	75	4,5	1.03
90	70.712.3090.17	90X5,4 SDR17 ISO S-8	90	5,4	1.47
110	70.712.3110.17	110X6,6 SDR17 ISO S-8	110	6,6	2.19
125	70.712.3125.17	125X7,4 SDR17 ISO S-8	125	7,4	2.79
140	70.712.3140.17	140X8,3 SDR17 ISO S-8	140	8,3	3.50
160	70.712.3160.17	160X9,5 SDR17 ISO S-8	160	9,5	4.57
180	70.712.3180.17	180X10,7 SDR17 ISO S-8	180	10,7	5.77
200	70.712.3200.17	200X11,9 SDR17 ISO S-8	200	11,9	7.12
225	70.712.3225.17	225X13,4 SDR17 ISO S-8	225	13,4	9.03
250	70.712.3250.17	250X14,8 SDR17 ISO S-8	250	14,8	11.10
280	70.712.3280.17	280X16,6 SDR17 ISO S-8	280	16,6	13.90
315	70.712.3315.17	315X18,7 SDR17 ISO S-8	315	18,7	17.60
355	70.712.3355.17	355X21,1 SDR17 ISO S-8	355	21,1	22.40
400	70.712.3400.17	400X23,7 SDR17 ISO S-8	400	23,7	28.30
75	70.712.3075.11	75X6,8 SDR11 ISO S-5	75	6,8	1.48
90	70.712.3090.11	90X8,2 SDR11 ISO S-5	90	8,2	2.14
110	70.712.3110.11	110X10,0 SDR11 ISO S-5	110	10	3.18
125	70.712.3125.11	125X11,4 SDR11 ISO S-5	125	11,4	4.12
140	70.712.3140.11	140X12,7 SDR11 ISO S-5	140	12,7	5.13
160	70.712.3160.11	160X14,6 SDR11 ISO S-5	160	14,6	6.74
180	70.712.3180.11	180X16,4 SDR11 ISO S-5	180	16,4	8.51
200	70.712.3200.11	200X18,2 SDR11 ISO S-5	200	18,2	10.50
225	70.712.3225.11	225X20,5 SDR11 ISO S-5	225	20,5	13.30
250	70.712.3250.11	250X22,7 SDR11 ISO S-5	250	22,7	16.30
280	70.712.3280.11	280X25,4 SDR11 ISO S-5	280	25,4	20.50
315	70.712.3315.11	315X28,6 SDR11 ISO S-5	315	28,6	25.90
355	70.712.3355.11	355X32,2 SDR11 ISO S-5	355	32,2	32.90

Dimension	Code	Detail	da(OD) mm	s mm	Weight
400	70.712.3400.11	400X36,3 SDR11 ISO S-5	400	36,3	41.70