

Saddles

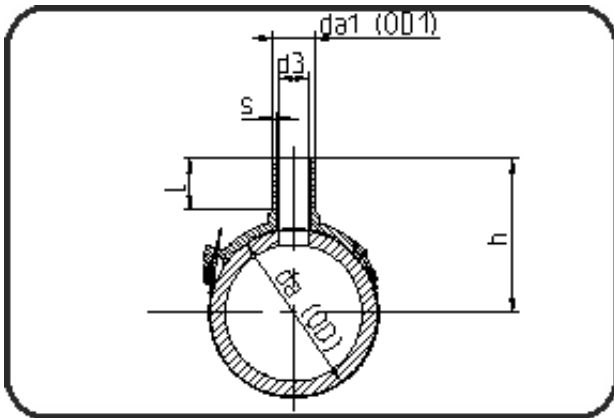

Code: 288

- Spigot saddle
- MOP water 16bar/gas 10bar
- W/P-TW
- injection moulded
- **Electro-fusion**
- **PE 100-RC black**

Dimension	Code	Detail	Weight
250/75	70.288.2575.11	250/75 SDR 17 - 11	0.73

	Unit	Nominale	Tol+	Tol-
da(OD)	mm	250	0.00	0.00
L	mm	86	1.00	1.00
b	mm	266	0.00	0.00
s	mm	6,8	0.80	0.00
alph	[°]	30	0.00	0.00
d3	mm	55	0.00	0.00
h	mm	251	0.00	0.00
da(OD1)	mm	75	0.50	0.00