

## Electro Fusion Fittings

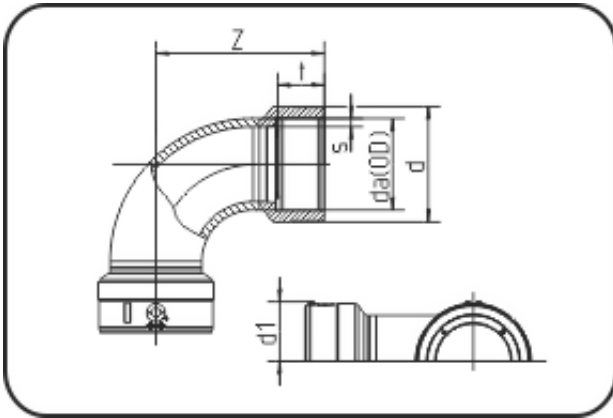

Code: 171.2

- **E-Elbow 90°**
- MOP water 16bar/gas 10bar
- W/P-TW
- with E-Spigot Couplers
- injection moulded+welded
- **Electro-fusion**
- **PE 100-RC black**

Dimension	Code	Detail	Weight
250	70.171.2250.11	250 SDR 17-11	17.70

	Unit	Nominale	Tol+	Tol-
da(OD)	mm	250	1.40	0.00
s	mm	22,7	2.40	0.00
d	mm	315	1.50	1.50
d1	mm	162,3	1.50	1.50
t	mm	127	3.00	3.00
z	mm	259	3.00	3.00