

Saddles

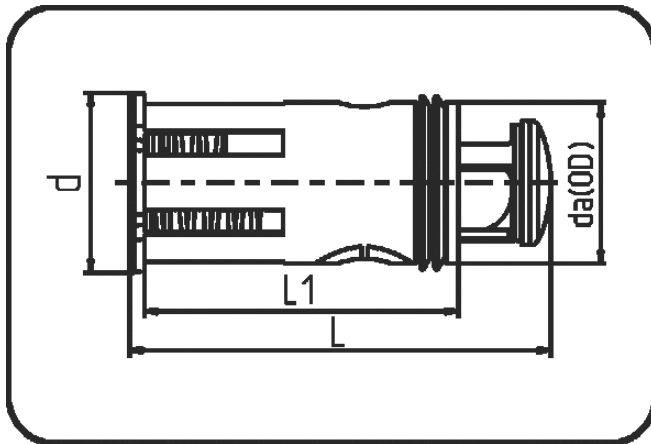

Code: 272

- **Gas-Lock**
- Gas excess flow valve
- pressure range: 1-5bar yellow
- injection moulded
- **PPA**

Dimension	Code	Detail	L2 mm	L3 mm	d3 mm	d mm	da(OD) mm	Weight
20	9P.272.1020.00	20 1-5 bar D25	52,5	40,2	12,9	17	20	0.01
32	9P.272.1032.00	32 1-5 bar D100	65,5	48,6	24,8	27,8	32	0.02