

Valves

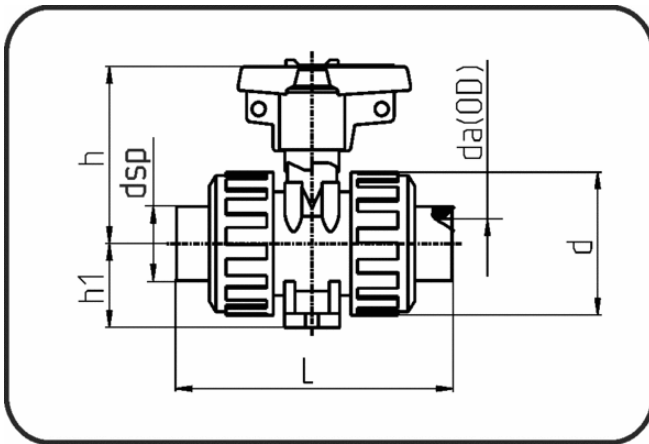

Code: 363.13

- Ball Valve M1
- FPM-sealing
- injection moulded
- Socket-welding
- PVDF natural

Dimension	Code	Detail	da(OD) mm	L mm	d mm	h mm	b mm	Weight
20	30.363.1320.21	20 - MOP 16 bar	20	98,5	56,5	74,5	40	0.29
25	30.363.1325.21	25 - MOP 16 bar	25	113	67	83	51,5	0.45
32	30.363.1332.21	32 - MOP 16 bar	32	123	73,5	85,5	51,5	0.58
40	30.363.1340.21	40 - MOP 16 bar	40	141	90	104,5	64	0.94
50	30.363.1350.21	50 - MOP 16 bar	50	165	105,5	113	73	1.41
63	30.363.1363.21	63 - MOP 16 bar	63	194,5	124,5	121,5	85	2.18
75	30.363.1375.21	75 - MOP 16 bar	75	231	157,5	151,5	110	1.89