

Valves

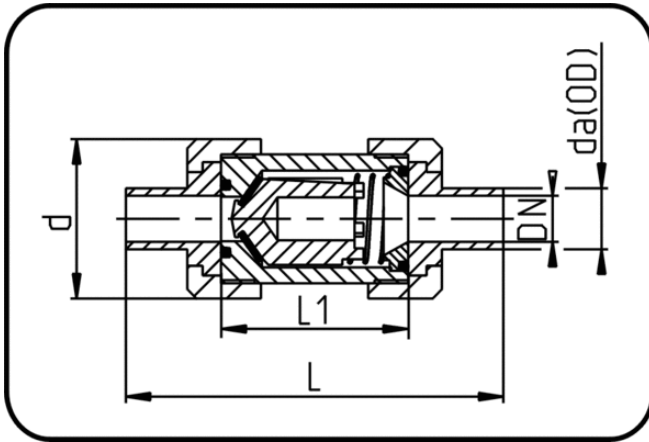

Code: 336.13

- Check Valve with Spring
- FPM-sealing
- injection moulded
- Butt + IR-welding
- PP Pure grey

Dimension	Code	Detail	da(OD) mm	L mm	L1 mm	d mm	p bar	DN mm	Weight
90	72.336.1390.17	90 - SDR17 ISO S-8	90	295	160	188	6	80	3.19
20	72.336.1320.11	20 - SDR11 ISO S-5	20	124	61	53	10	15	0.11
25	72.336.1325.11	25 - SDR11 ISO S-5	25	143	69	63	10	20	0.18
32	72.336.1332.11	32 - SDR11 ISO S-5	32	151	72	70,5	10	25	0.23
40	72.336.1340.11	40 - SDR11 ISO S-5	40	171	83	85,5	10	32	0.39
50	72.336.1350.11	50 - SDR11 ISO S-5	50	190,5	94	100,5	10	40	0.59
63	72.336.1363.11	63 - SDR11 ISO S-5	63	220	108	118	10	50	0.92
75	72.336.1375.11	75 - SDR11 - MOP 8 bar	75	279	135	151	10	65	1.87