

Valves

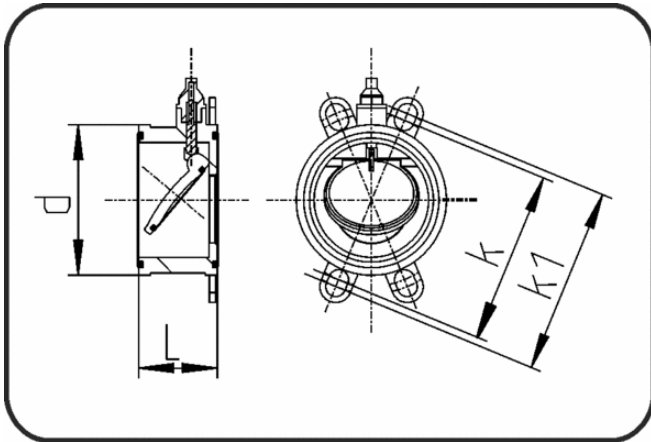

Code: 258

- Swing check valve K4 + Spring
- FPM-sealing
- Flange connection DIN/ANSI/JIS
- PVDF natural

Dimension	Code	Detail	da(OD) mm	DN mm	L mm	d mm	k mm	k1 mm	Weight
75	30.258.0075.33	DN 65 da 75 MOP 10 bar	75	65	63	115	139	145	0.54
90	30.258.0090.33	DN 80 da 90 MOP 10 bar	90	80	71	128	150	160	0.70
110	30.258.0110.33	DN 100 da 110 MOP 10 bar	110	100	80	155	175	191	1.05
160	30.258.0160.33	DN 150 da 160 MOP 10 bar	160	150	106	212	234	242	2.63
225	30.258.0225.33	DN 200 da 225 MOP 10 bar	225	200	140	264	290	299	4.90
280	30.258.0280.33	DN 250 da 280 MOP 10 bar	280	250	140	325	350	362	7.94