

Valves

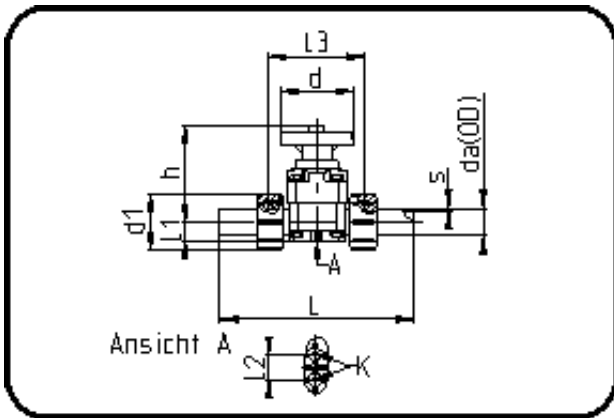

Code: 340

- Diaphragm Valve
- manually controlled
- EPDM/PTFE diaphragm
- Union Connection
- PVDF UHP natural

Dimension	Code	Detail	Weight
63	35.340.0063.21	63 - SDR21 MOP 10 bar	3.21

	Unit	Nominale	Tol+	Tol-
da(OD)	mm	63	0.00	0.00
L	mm	322	0.00	0.00
L1	mm	38,5	0.75	0.75
L3	mm	184	3.00	3.00
L2	mm	44	0.75	0.75
DN	mm	50	0.00	0.00
s	mm	3	0.00	0.00
d	mm	136	1.50	1.50
d1	mm	110	0.00	0.00
Kv-I	min	875	0.00	0.00
h	mm	170	3.00	3.00
K	mm	M8	0.00	0.00