

Fittings with short Spigot

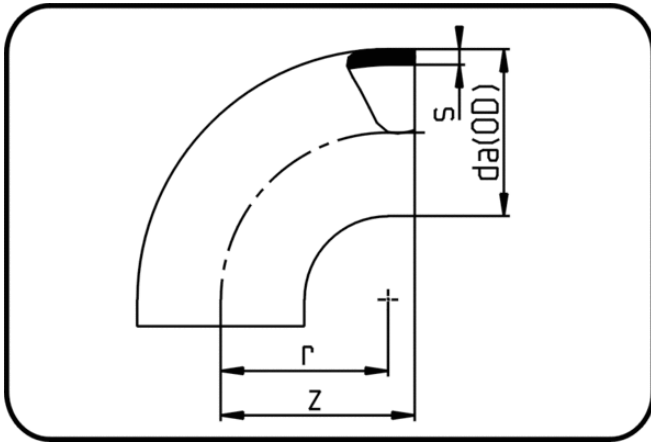

Code: 001

- Bend 90°
- short spigot
- injection moulded
- **Butt-welding**
- **PPR grey**

Dimension	Code	Detail	da(OD) mm	s mm	z mm	r mm	Weight
110	11.001.0110.33	110X3,4 SDR33 ISO S-16	110	3,4	120	110	0.24
125	11.001.0125.33	125X3,9 SDR33 ISO S-16	125	3,9	140	125	0.33
140	11.001.0140.33	140X4,3 SDR33 ISO S-16	140	4,3	150	140	0.46
160	11.001.0160.33	160X4,9 SDR33 ISO S-16	160	4,9	180	155	0.73
180	11.001.0180.33	180X5,5 SDR33 ISO S-16	180	5,5	200	180	0.96
200	11.001.0200.33	200X6,2 SDR33 ISO S-16	200	6,2	220	200	1.36
225	11.001.0225.33	225X6,9 SDR33 ISO S-16	225	6,9	245	225	1.81
250	11.001.0250.33	250X7,7 SDR33 ISO S-16	250	7,7	290	265	2.74
280	11.001.0280.33	280X8,6 SDR33 ISO S-16	280	8,6	290	260	3.60
315	11.001.0315.33	315X9,7 SDR33 ISO S-16	315	9,7	340	300	4.96
355	11.001.0355.33	355X10,9 SDR33 ISO S-16	355	10,9	340	300	6.36
400	11.001.0400.33	400X12,3 SDR33 ISO S-16	400	12,3	345	300	8.20
450	11.001.0450.33	450X13,8 SDR33 ISO S-16	450	13,8	445	400	14.18
500	11.001.0500.33	500X15,3 SDR33 ISO S-16	500	15,3	445	400	17.56
63	11.001.0063.17	63X3,8 SDR17 ISO S-8	63	3,8	70	63	0.08
75	11.001.0075.17	75X4,5 SDR17 ISO S-8	75	4,5	85	75	0.14
90	11.001.0090.17	90X5,4 SDR17 ISO S-8	90	5,4	100	90	0.23
110	11.001.0110.17	110X6,6 SDR17 ISO S-8	110	6,6	123	110	0.41
125	11.001.0125.17	125X7,4 SDR17 ISO S-8	125	7,4	140	125	0.60
140	11.001.0140.17	140X8,3 SDR17 ISO S-8	140	8,3	150	140	0.79
160	11.001.0160.17	160X9,5 SDR17 ISO S-8	160	9,5	180	155	1.26
180	11.001.0180.17	180X10,7 SDR17 ISO S-8	180	10,7	200	180	1.76
200	11.001.0200.17	200X11,9 SDR17 ISO S-8	200	11,9	220	200	2.41
225	11.001.0225.17	225X13,4 SDR17 ISO S-8	225	13,4	245	225	3.34
250	11.001.0250.17	250X14,8 SDR17 ISO S-8	250	14,8	285	265	4.96
280	11.001.0280.17	280X16,6 SDR17 ISO S-8	280	16,6	290	265	6.20
315	11.001.0315.17	315X18,7 SDR17 ISO S-8	315	18,7	340	300	9.02
355	11.001.0355.17	355X21,1 SDR17 ISO S-8	355	21,1	340	300	11.60

Dimension	Code	Detail	da(OD) mm	s mm	z mm	r mm	Weight
400	11.001.0400.17	400X23,7 SDR17 ISO S-8	400	23,7	340	300	14.48
450	11.001.0450.17	450X26,7 SDR17 ISO S-8	450	26,7	445	400	24.24
500	11.001.0500.17	500X29,7 SDR17 ISO S-8	500	29,7	445	400	30.32
20	11.001.0020.11	20X1,9 SDR11 ISO S-5	20	1,9	32	23	0.01
25	11.001.0025.11	25X2,3 SDR11 ISO S-5	25	2,3	38	30	0.01
32	11.001.0032.11	32X2,9 SDR11 ISO S-5	32	2,9	43	32	0.02
40	11.001.0040.11	40X3,7 SDR11 ISO S-5	40	3,7	46	40	0.04
50	11.001.0050.11	50X4,6 SDR11 ISO S-5	50	4,6	58	50	0.07
63	11.001.0063.11	63X5,8 SDR11 ISO S-5	63	5,8	70	63	0.11
75	11.001.0075.11	75X6,8 SDR11 ISO S-5	75	6,8	85	75	0.18
90	11.001.0090.11	90X8,2 SDR11 ISO S-5	90	8,2	100	90	0.33
110	11.001.0110.11	110X10,0 SDR11 ISO S-5	110	10	124	110	0.59
125	11.001.0125.11	125X11,4 SDR11 ISO S-5	125	11,4	140	125	0.88
140	11.001.0140.11	140X12,7 SDR11 ISO S-5	140	12,7	150	140	1.18
160	11.001.0160.11	160X14,6 SDR11 ISO S-5	160	14,6	180	155	1.84
180	11.001.0180.11	180X16,4 SDR11 ISO S-5	180	16,4	200	180	2.60
200	11.001.0200.11	200X18,2 SDR11 ISO S-5	200	18,2	220	200	3.42
225	11.001.0225.11	225X20,5 SDR11 ISO S-5	225	20,5	243	225	4.96
250	11.001.0250.11	250X22,7 SDR11 ISO S-5	250	22,7	290	265	7.44
280	11.001.0280.11	280X25,4 SDR11 ISO S-5	280	25,4	290	265	8.92
315	11.001.0315.11	315X28,6 SDR11 ISO S-5	315	28,6	340	300	13.54
355	11.001.0355.11	355X32,2 SDR11 ISO S-5	355	32,2	340	300	17.36
400	11.001.0400.11	400X36,3 SDR11 ISO S-5	400	36,3	345	300	22.00
450	11.001.0450.11	450X40,9 SDR11 ISO S-5	450	40,9	445	400	35.56
500	11.001.0500.11	500X45,4 SDR11 ISO S-5	500	45,4	445	400	44.46