

## PPR-Liner without Pre-Treatment

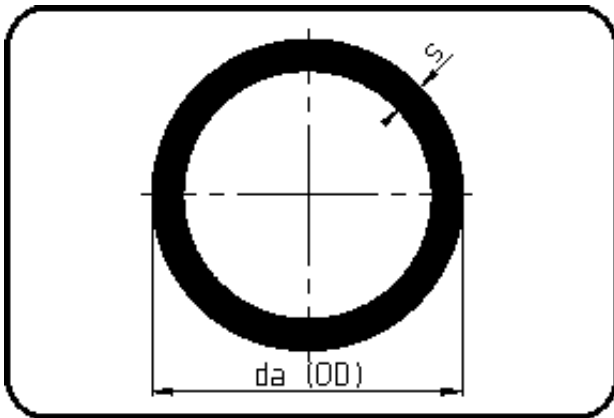

Code: 762

- Pipe 6.2m
- extruded
- PPR grey

| Dimension | Code           | Detail              | Weight |
|-----------|----------------|---------------------|--------|
| 355       | 11.762.0355.00 | 355X6,0 Ventilation | 6.38   |

|        | Unit | Nominale | Tol+ | Tol- |
|--------|------|----------|------|------|
| da(OD) | mm   | 355      | 3.20 | 0.00 |
| s      | mm   | 6        | 0.70 | 0.00 |