

Valves

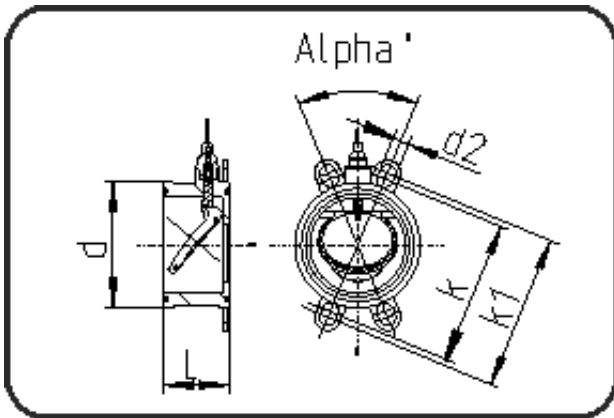

Code: 258.3

- Swing check valve K4 + Spring
- EPDM-sealing
- Flange connection DIN/ANSI/JIS
- PP-FRP grey

Dimension	Code	Detail	Weight
225	11.258.3225.11	DN 200 da 225 MOP 10 bar	3.28

	Unit	Nominale	Tol+	Tol-
da(OD)	mm	225	2.10	0.00
L	mm	140	0.75	0.75
k1	mm	299	0.75	0.75
DN	mm	200	0.00	0.00
d	mm	264	0.75	0.75
alph	[°]	45	0.75	0.75
d2	mm	24	0.75	0.75
k	mm	290	0.75	0.75