

Valves

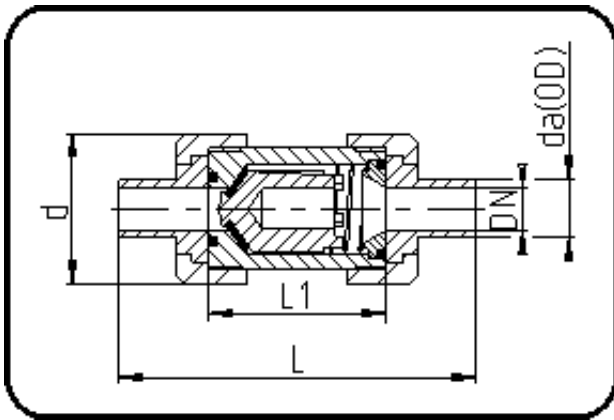

Code: 336.12

- Check Valve with Spring
- EPDM-sealing
- injection moulded
- **Butt + IR-welding**
- **PP grey**

Dimension	Code	Detail	Weight
20	11.336.1220.11	20 - SDR11 ISO S-5	0.11

	Unit	Nominale	Tol+	Tol-
da(OD)	mm	20	0.30	0.00
L	mm	124	7.50	7.50
L1	mm	61	0.00	0.00
DN	mm	15	0.00	0.00
d	mm	53	0.75	0.75
p	bar	10	0.00	0.00