

## Valves

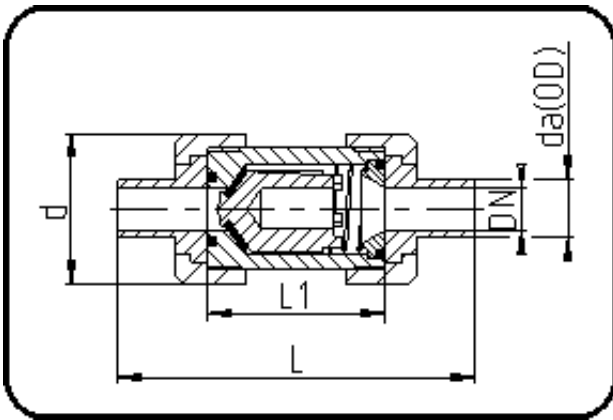

Code: 336.13

- Check Valve with Spring
- FPM-sealing
- injection moulded
- **Butt + IR-welding**
- **PP Pure grey**

Dimension	Code	Detail	Weight
32	72.336.1332.11	32 - SDR11 ISO S-5	0.23

	Unit	Nominale	Tol+	Tol-
da(OD)	mm	32	0.00	0.00
L	mm	151	7.50	7.50
L1	mm	72	0.75	0.75
DN	mm	25	0.00	0.00
d	mm	70,5	0.75	0.75
p	bar	10	0.00	0.00