

PPR-Liner without Pre-Treatment

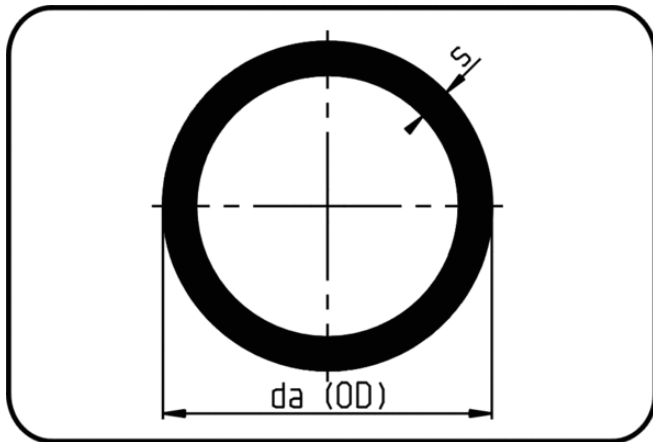

Code: 762

- Pipe 5.2m
- extruded
- PPR grey

Dimension	Code	Detail	da(OD) mm	s mm	Weight
32	11.762.0032.09	32X3,6 SDR9 ISO S-4	32	3,6	0.31