

Valves

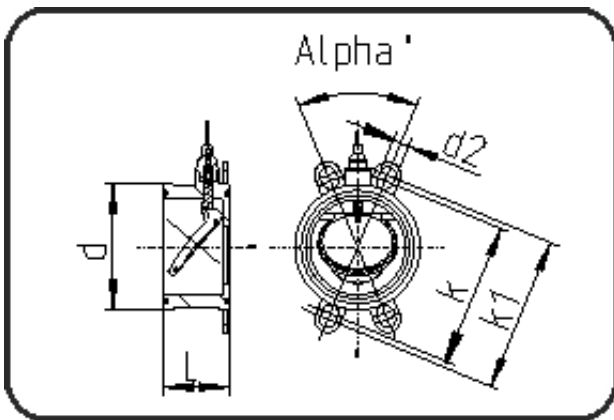

Code: 258.3

- Swing check valve K4 + Spring
- EPDM-sealing
- Flange connection DIN/ANSI/JIS
- PP-FRP grey

Dimension	Code	Detail	Weight
280	11.258.3280.11	DN 250 da 280 MOP 8 bar	5.31

	Unit	Nominale	Tol+	Tol-
da(OD)	mm	280	2.60	0.00
L	mm	140	0.75	0.75
k1	mm	362	0.75	0.75
DN	mm	250	0.00	0.00
d	mm	325	0.75	0.75
alph	[°]	30	0.75	0.75
d2	mm	27	0.75	0.75
k	mm	350	0.75	0.75