

E-Schweissbare Fittings

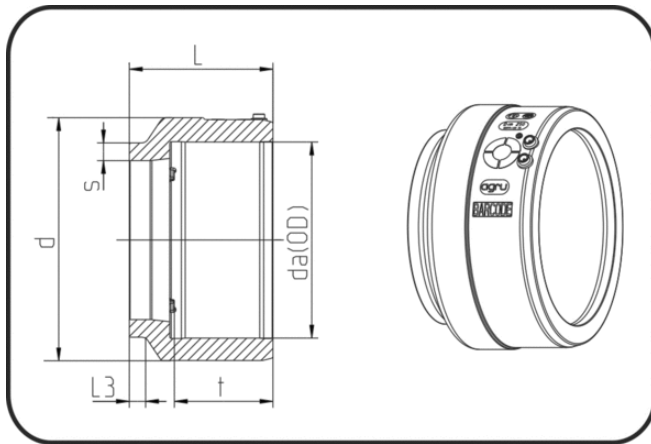

Code: 172

- E-Anschweißmuffe
- MOP Wasser 16bar / Gas 10bar
- W/P-TW
- formgespritzt
- **Stumpf + E-Muffenschweissung**
- **PE 100-RC schwarz**

Dimension	Code	Detail	da(OD) mm	s mm	L mm	L3 mm	d mm	t mm	Gewicht
250	70.172.0250.11	250 SDR 11	250	22,7	185	20	315	126	4.89