

## Verlängerte Fittings

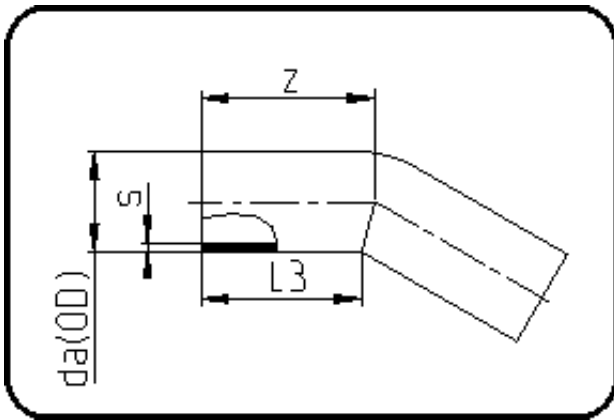

Code: 019

- Winkel 30°
- lange Schenkel
- W/P-TW
- formgespritzt
- **Stumpf + E-Muffenschweissung**
- **PE 100-RC schwarz**

Dimension	Code	Detail	Gewicht
160	70.019.0160.11	160X14,6 SDR11 PN16	3.46

	Einheit	Nominale	Tol+	Tol-
da(OD)	mm	160	0.00	0.00
L3	mm	206	7.50	7.50
s	mm	14,6	0.00	0.00
z	mm	230	7.50	7.50