

Schellen

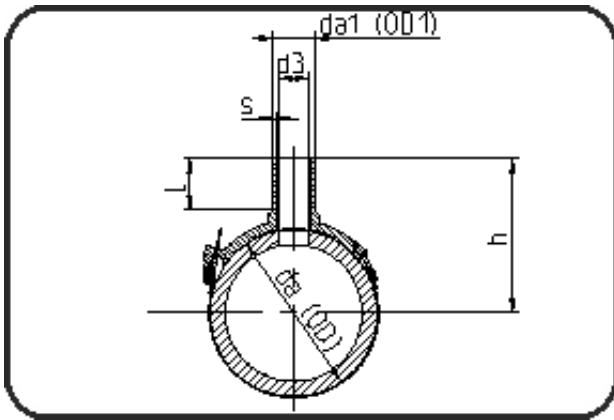

Code: 288

- **Stutzenschelle**
- MOP Wasser 16bar / Gas 10bar
- W/P-TW
- formgespritzt
- **Heizwendel-Schweissung**
- **PE 100-RC schwarz**

Dimension	Code	Detail	Gewicht
90/32	70.288.9032.11	90/32 SDR 17 - 11	0.28

	Einheit	Nominale	Tol+	Tol-
da(OD)	mm	90	0.00	0.00
L	mm	60	1.00	1.00
b	mm	120	0.00	0.00
s	mm	3	0.40	0.00
alph	[°]	0	0.00	0.00
d3	mm	24	0.00	0.00
h	mm	130	3.00	3.00
da(OD1)	mm	32	0.30	0.00