

Schellen

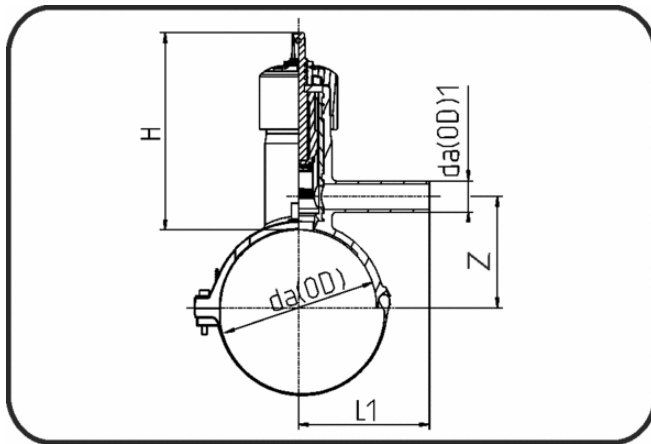

Code: 70.079

- Druckanbohrventil
- Messingventil+Schneidschraube
- W/P-TW
- formgespritzt
- Heizwendel-Schweissung
- PE 100-RC schwarz

Zum Betätigen des Druckanbohrventils wird eine Einbaugarnitur benötigt.

Dimension	Code	Detail	da(OD) mm	L1 mm	h mm	z mm	da(OD1) mm	Gewicht
63/32	70.079.6332.11	63/32 SDR11 PN16	63	131	163	65,3	32	1.60
63/40	70.079.6340.11	63/40 SDR11 PN16	63	140	163	65,3	40	1.58
63/50	70.079.6350.11	63/50 SDR11 PN16	63	160,5	163	65,3	50	1.65
63/63	70.079.6363.11	63/63 SDR11 PN16	63	187	163	65,3	63	1.71
90/32	70.079.9032.11	90/32 SDR 17 - 11 PN16	90	135	203	79	32	2.38
90/40	70.079.9040.11	90/40 SDR 17 - 11 PN16	90	145	203	79	40	2.41
90/50	70.079.9050.11	90/50 SDR 17 - 11 PN16	90	161	203	79	50	2.44
90/63	70.079.9063.11	90/63 SDR 17 - 11 PN16	90	192	203	79	63	2.48
110/32	70.079.1132.11	110/32 SDR 17 - 11 PN16	110	137	202	87	32	2.46
110/40	70.079.1140.11	110/40 SDR 17 - 11 PN16	110	147	203	87	40	2.50
110/50	70.079.1150.11	110/50 SDR 17 - 11 PN16	110	160	203	87	50	2.48
110/63	70.079.1163.11	110/63 SDR 17 - 11 PN16	110	192,6	203	87	63	2.56
125/32	70.079.1232.11	125/32 SDR 17 - 11 PN16	125	137	203	95,9	32	2.49
125/40	70.079.1240.11	125/40 SDR 17 - 11 PN16	125	147	203	95,9	40	2.49
125/50	70.079.1250.11	125/50 SDR 17 - 11 PN16	125	161	203	95,9	50	2.52
125/63	70.079.1263.11	125/63 SDR 17 - 11 PN16	125	192	203	95,9	63	2.61
140/32	70.079.1432.11	140/32 SDR 17 - 11 PN16	140	137	203	103,5	32	2.46
140/40	70.079.1440.11	140/40 SDR 17 - 11 PN16	140	147	203	103,5	40	2.50
140/50	70.079.1450.11	140/50 SDR 17 - 11 PN16	140	161	203	103,5	50	2.52
140/63	70.079.1463.11	140/63 SDR 17 - 11 PN16	140	192	203	103,4	63	2.60
160/32	70.079.1632.11	160/32 SDR 17 - 11 PN16	160	137	203	103,4	32	2.55
160/40	70.079.1640.11	160/40 SDR 17 - 11 PN16	160	147	203	113,2	40	2.56
160/50	70.079.1650.11	160/50 SDR 17 - 11 PN16	160	161	203	113,2	50	2.60
160/63	70.079.1663.11	160/63 SDR 17 - 11 PN16	160	189	203	113,2	63	2.68
180/32	70.079.1832.11	180/32 SDR 17 - 11 PN16	180	137	203	123	32	2.64
180/40	70.079.1840.11	180/40 SDR 17 - 11 PN16	180	147	203	123	40	2.62
180/50	70.079.1850.11	180/50 SDR 17 - 11 PN16	180	161	203	123	50	2.69

Dimension	Code	Detail	da(OD) mm	L1 mm	h mm	z mm	da(OD1) mm	Gewicht
180/63	70.079.1863.11	180/63 SDR 17 - 11 PN16	180	189	203	123	63	2.77
200/32	70.079.2032.11	200/32 SDR 17 - 11 PN16	200	137	203	134	32	2.50
200/40	70.079.2040.11	200/40 SDR 17 - 11 PN16	200	146	203	134	40	2.50
200/50	70.079.2050.11	200/50 SDR 17 - 11 PN16	200	159	203	134	50	2.55
200/63	70.079.2063.11	200/63 SDR 17 - 11 PN16	200	191	203	134	63	2.62
225/32	70.079.2232.11	225/32 SDR 17 - 11 PN16	225	137	203	147,6	32	2.55
225/40	70.079.2240.11	225/40 SDR 17 - 11 PN16	225	147	203	147,6	40	2.34
225/50	70.079.2250.11	225/50 SDR 17 - 11 PN16	225	160	203	147,6	50	2.60
225/63	70.079.2263.11	225/63 SDR 17 - 11 PN16	225	192	203	147,6	63	2.60
250/63	70.079.2563.11	250/63 SDR 17 - 11 PN16	250	224,5	203	169,6	63	2.50
280/63	70.079.2863.11	280/63 SDR 17 - 11 PN16	280	224,5	203	184,6	63	2.77
315/63	70.079.3163.11	315/63 SDR 17 - 11 PN16	315	192	203	203,6	63	2.80
355/63	70.079.3563.11	355/63 SDR 17 - 11 PN16	355	192	203	203	63	2.80