

## Schellen

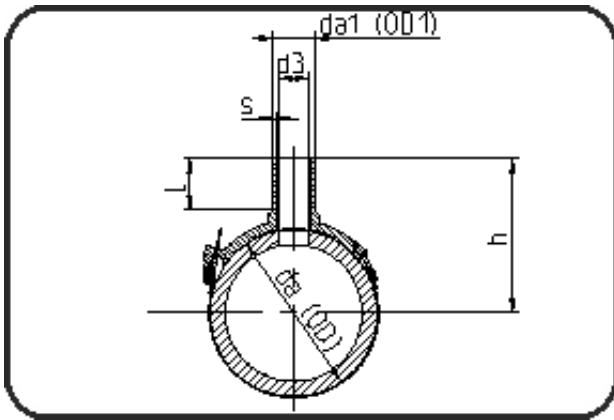

Code: 288

- **Stützschelle**
- MOP Wasser 16bar / Gas 10bar
- W/P-TW
- formgespritzt
- **Heizwendel-Schweissung**
- **PE 100-RC schwarz**

Dimension	Code	Detail	Gewicht
225/63	70.288.2263.11	225/63 SDR 17 - 11	0.44

	Einheit	Nominale	Tol+	Tol-
da(OD)	mm	225	0.00	0.00
L	mm	77	1.50	1.50
b	mm	244,5	0.00	0.00
s	mm	5,8	0.70	0.00
alph	[°]	40	0.00	0.00
d3	mm	45	0.00	0.00
h	mm	219	0.00	0.00
da(OD1)	mm	63	0.40	0.00