

E-Schweissbare Fittings

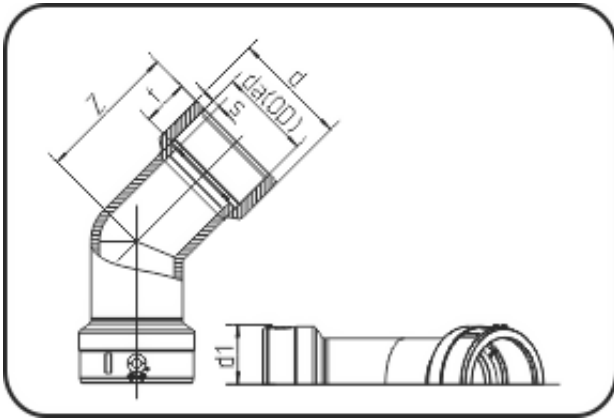

Code: 170.2

- E-Winkel 45°
- MOP Wasser 16bar / Gas 10bar
- W/P-TW
- mit E-Anschweißmuffen
- formgespritzt+geschweisst
- **Heizwendel-Schweissung**
- **PE 100-RC schwarz**

Dimension	Code	Detail	Gewicht
250	70.170.2250.11	250 SDR 17-11	16.90

	Einheit	Nominale	Tol+	Tol-
da(OD)	mm	250	1.40	0.00
s	mm	22,7	2.40	0.00
d	mm	315	1.50	1.50
d1	mm	162,3	1.50	1.50
t	mm	127	3.00	3.00
z	mm	386	3.00	3.00