

Verlängerte Fittings

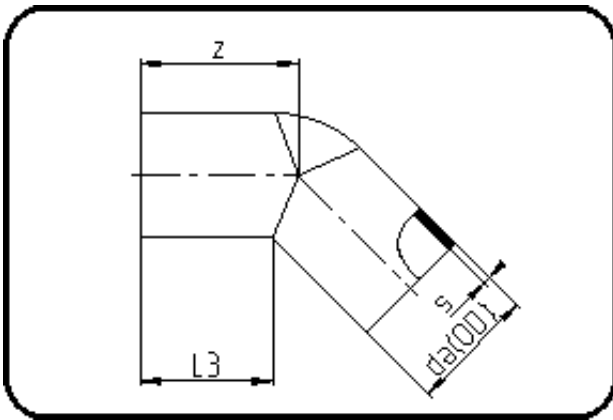

Code: 060

- Winkel 45°
- lange Schenkel
- W/P-TW
- formgespritzt
- **Stumpf + E-Muffenschweissung**
- **PE 100-RC schwarz**

Dimension	Code	Detail	Gewicht
110	70.060.0110.11	110X10,0 SDR11 PN16	0.76

	Einheit	Nominale	Tol+	Tol-
da(OD)	mm	110	0.70	0.00
L3	mm	82	1.50	1.50
s	mm	10	1.10	0.00
z	mm	108	1.50	1.50