

## E-Schweissbare Fittings

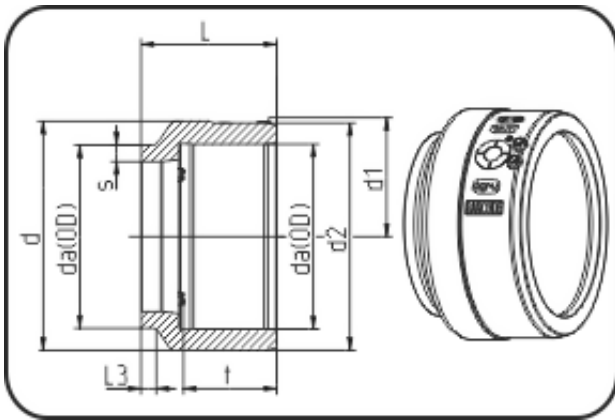

Code: 172

- E-Anschweißmuffe
- MOP Wasser 16bar / Gas 10bar
- W/P-TW
- formgespritzt
- **Stumpf + E-Muffenschweissung**
- PE 100-RC schwarz

Dimension	Code	Detail	Gewicht
250	70.172.0250.11	250 SDR 11	4.89

	Einheit	Nominale	Tol+	Tol-
da(OD)	mm	250	2.30	0.00
L	mm	185	3.00	0.00
L3	mm	20	1.50	0.00
s	mm	22,7	2.40	0.00
d	mm	315	1.90	0.00
d1	mm	162,3	1.00	1.00
t	mm	126	0.00	2.00
d2	mm	310	2.00	2.00