

PE/PE Simultanschweissung

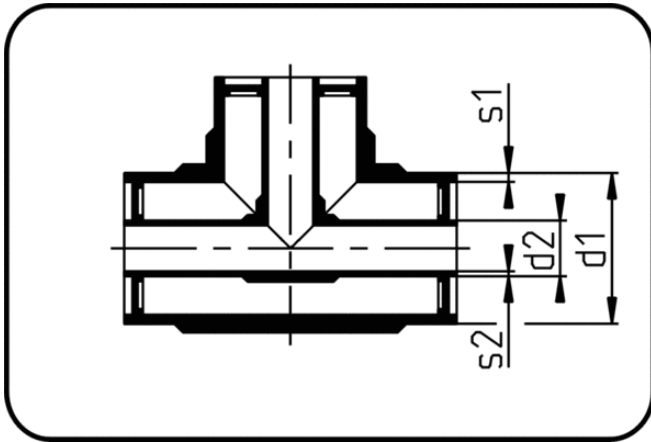

Code: 106

- T-Stück
- formgespritzt+vormontiert
- **Simultanschweissung**
- PE 100-RC/PE 100-RC

Dimension	Code	Detail	SDR1	SDR2	s1 mm	s2 mm	d1 mm	d2 mm	Gewicht
160/90	82.106.1690.37	160/90 SDR33/17	33	17	4,9	5,4	160	90	1.80
160/90	82.106.1690.31	160/90 SDR33/11	33	11	4,9	8,2	160	90	1.96
315/200	82.106.3120.31	315/200 SDR33/11	33	11	9,7	18,2	315	200	16.43
355/250	82.106.3525.31	355/250 SDR33/11	33	11	10,9	22,7	355	250	37.60