

PE/PE Simultanschweissung

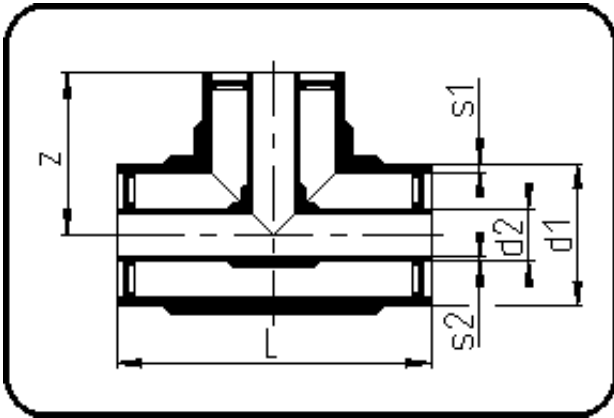

Code: 106

- T-Stück
- formgespritzt+vormontiert
- **Simultanschweissung**
- PE 100-RC/PE 100-RC

Dimension	Code	Detail	Gewicht
315/200	82.106.3120.31	315/200 SDR33/11	16.43

	Einheit	Nominale	Tol+	Tol-
L	mm	536	0.00	0.00
d1	mm	315	0.00	0.00
SDR2		11	0.00	0.00
SDR1		33	0.00	0.00
s2	mm	18,2	0.00	0.00
d2	mm	200	0.00	0.00
s1	mm	9,7	0.00	0.00
z	mm	270	0.00	0.00